

LIST OF MATERIALS

POS.	DESCRIPTION
5	BODY
15	PLUG
25	LOWER BONNET
60	STEM
80	GLAND
105	INDICATOR
151	STEM GUIDE
220	PACKING
281	METAL GASKET
289	HANDLE GASKET
352	ADJUSTABLE BOLT
355	BODY BONNET STUD
360	BODY BONNET STUD NUT
401	GLAND BOLT
557	SLIP WASHER
558	THRUST WASHER
575	ANTISTATIC SPRING
610	HANDLE
620	HAND HOLD
650	GREASE FITTING
788	INJECTION VALVE
790	CHECK VALVE

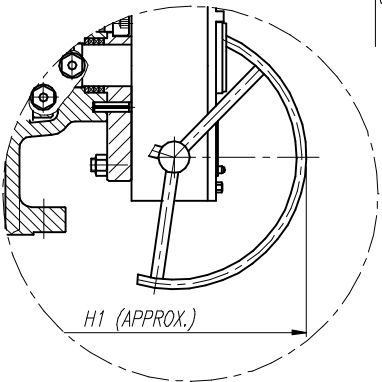
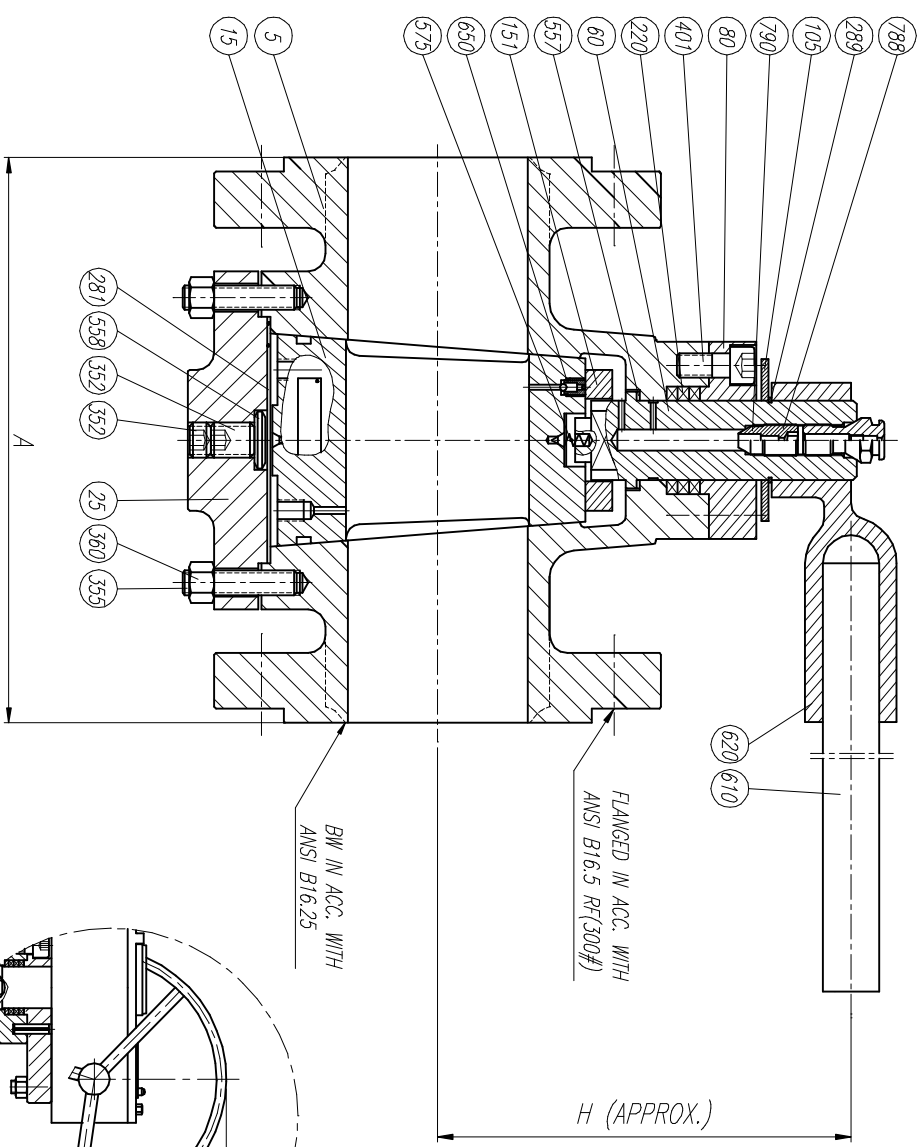

ELECTRICAL AND PNEUMATIC OPERATION UPON REQUEST

SIZE	A	H	WEIGHT	SIZE	A	H1	WEIGHT
1/2"	130	120	10	6"	403	420	180
3/4"	150	121	11	8"	502	495	235
1"	159	123	12	10"	568	590	300
1 1/2"	191	144	18	12"	711	705	455
2"	216	171	23	14"	762	750	690
2 1/2"	241	196	29	16"	838	825	800
3"	283	224	32	18"	914	910	990
4"	305	262	69				

REV		Description		Drawn		Date		Approved		Date	
		GENERAL ASSEMBLY & LIST OF MATERIALS		Title: PLUG VALVE 300#		Size: A3		Drwg No.: PR031		REV: 0	
Drawn	ALD	Date	1/12/03	Gen Tol	ISO 4	Scale		Sheet	1 / 1	Approved	