



ANCV Series

Axial Nozzle Check Valve



Description

Check valves are used in numerous installations for various purposes and it is always a challenge for the planning engineer to find suitable return flow preventers. Often it does not become evident until a plant is being run on test that the selected non return valves slam heavily and produce high pressure peaks which exceed the permissible pressure to such an extent that the installation and the surroundings are endangered. A further important factor in the present and future is economy (the savings of energy).

A feature of the Samson Ringo Axial Flow Check Valves is its inherent non slam characteristic. This is achieved because the valve reacts so quickly to flow changes. This causes that the valve change the point of closure without letting any possible reverse flow. This avoid water hammer effect for liquid service and ensures no chance of reverse flow into the compressor for gas service.

Additional benefits of the Samson Ringo Axial Flow Check Valves design are:

- Low pressure drop and turbulence due to the streamlined flow path
- Extremely long service life because the moving parts are not subjected to the shocks associated with typical asymmetric valve designs
- The valve has no soft parts to wear, cause misalignment, or need replacing.

Design characteristics range

Design Temperature	Up to 650°C
Size	4" to 60"
Rating	150# to 1500#
Connection types	Flanged: RF, RTJ, FF according to ASME B16.5, B16.47 BW according to ASME B16.25 HUB ends (supplied with or without clamps) Other connections according to NORSOK, GOST, DIN are available on request

Design options

Samson Ringo offers to its customers two different design of the Axial Flow Check Valves:

■ Solid disc design

This is the design commonly used for valves below 12"

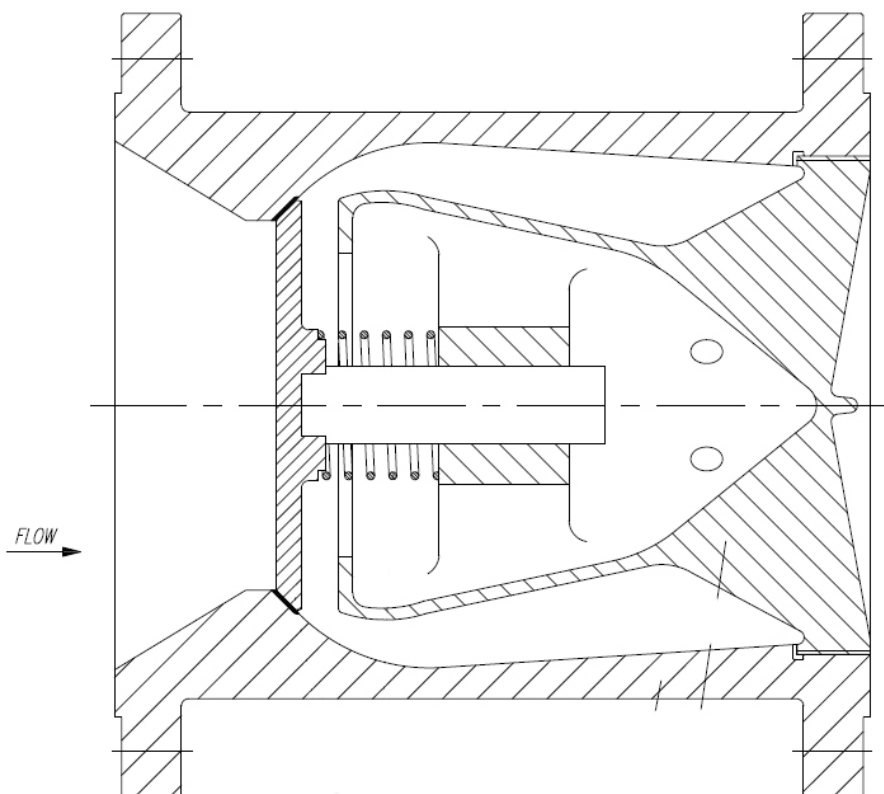

■ Ring disc design

In this design, typically used for sizes 14" and above, main advantages are the low friction, quick response and low pressure loss.

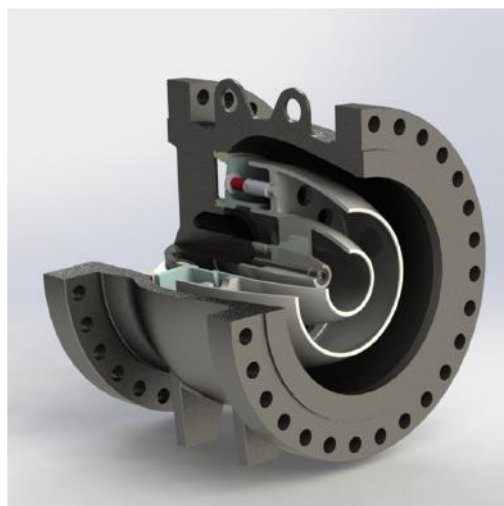

Materials

■ Body

Carbon Steel : A216-WCB/WCC

Cr-Mo Alloy Steel : A217-WC6, A217-WC9

Cr-Mo-V Alloy Steel : A217-C12A

Nickel based alloys, Hastelloy, Inconel; Monel.

Titanium.

■ Trim

Martensitic : A217 Gr, CA15

Austenitic: A351 Gr, CF8/CF8M

Stainless steel 18% Cr: A351-CF8M, A351-CF8C

Cr + Ni Stainless steels: Alloy 20, A351-CK3MCuN

Duplex A890-Gr. 4A, Super Duplex A890-Gr. 6A

Nickel based alloys, Hastelloy, Inconel; Monel

Titanium.

■ Cladding and overlays

Stellite: Hardness HRC 45 RC & Maximum working temperature 500°C

Tungsten carbide: Hardness HRC 74 RC & Maximum working temperature 550°C

