

### LIST OF MATERIALS

POS.	PART NAME	MATERIAL
5	BODY	A105
10	ADAPTOR	A105
15	BALL	A105 + ENP
60	SHAFT	A479 T410
70	SEAT	PTFE
170	SUPPORT FLANGE	A105
240	BODY ADAPTOR GASKET	GRAPHITE
241	STEM GASKET	GRAPHITE
288	UPPER FLANGE GASKET	GRAPHITE
295	BODY ADAPTOR O-RING	VITON
335	STEM "O" RING	VITON
353	HANDLE BOLT	A193 B7
385	BODY ADAPTOR STUD	A193 B7
390	BODY ADAPTOR STUD NUT	A194 2H
421	SUPPORT FLANGE BOLT	A193 B7
610	HANDLE PLATE	CARBON STEEL
620	HANDLE	CARBON STEEL

OTHERS MATERIALS AVAILABLE UPON REQUEST

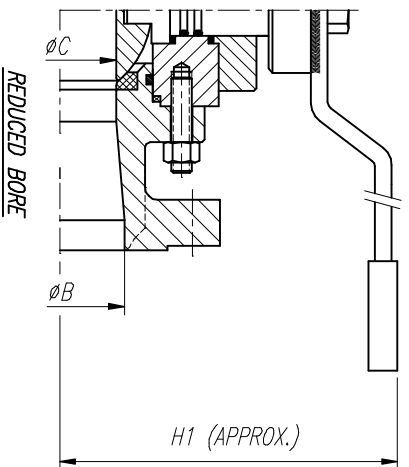
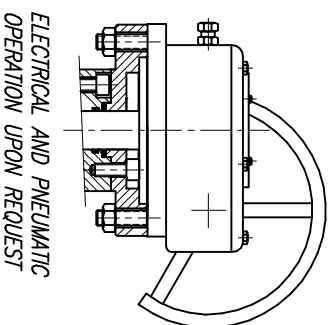
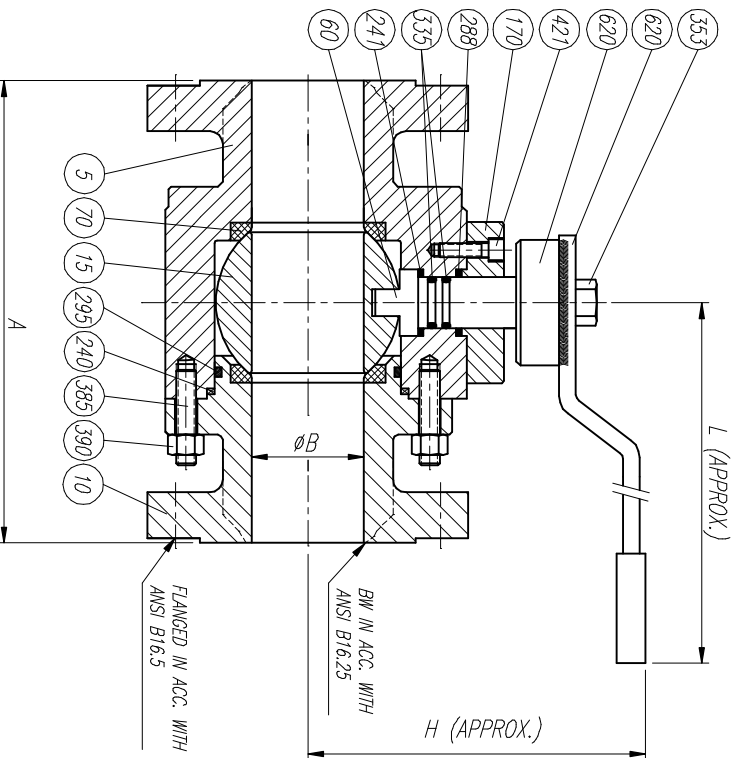

SIZE	A				ØB	ØC	H	H1	L	WEIGHT
	BW	RF	RTU	A						
1/2"	140	140	151	11	11	—	73	—	150	8
3/4"	152.5	152.5	165	20	11	75	73	180	10	10
1"	165	165	178	25	20	80	75	180	13	13
1 1/2"	190.5	190.5	203	38	25	100	80	280	22	22
2"	216	216	231	51	38	136	100	280	33	33
3"	283	283	298	76	51	165	136	380	50	50
4"	305	305	320	102	76	195	165	480	90	90
6"	457	403	419	152	102	250	195	GEAR	190	190

REV	Description	Drawn	Date	Appr

		<b>RINGO VALVULAS</b> GENERAL ASSEMBLY & LIST OF MATERIALS		Title: <b>FLOATING BALL VALVE</b> 300#	
Drawn	JLO	Date	20/12/03	Scale	A3
Appr					
Description: <b>Detail</b>				Drawn: <b>Date</b>	
Description: <b>Gen Tol ± 0.4</b>				Drawn: <b>Date</b>	
Sheet: <b>1</b>				Appr: <b>Date</b>	
Scale: <b>1:1</b>				Drawn No: <b>BR03FA1</b>	
Size: <b>A3</b>				REV: <b>0</b>	