

LIST OF MATERIALS

POS.	PART NAME	MATERIAL
5	BODY	A105
10	ADAPTOR	A105
15	BALL	A105 + ENP
60	SHAFT	A479 T410
70	SEAT	PTFE
170	SUPPORT FLANGE	A105
240	BODY ADAPTOR GASKET	GRAPHITE
241	STEM GASKET	GRAPHITE
288	UPPER FLANGE GASKET	GRAPHITE
295	BODY ADAPTOR O-RING	VITON
335	STEM "O" RING	VITON
353	HANDLE BOLT	A193 B7
421	SUPPORT FLANGE BOLT	A193 B7
610	HANDLE PLATE	CARBON STEEL
620	HANDLE	CARBON STEEL

OTHERS MATERIALS AVAILABLE UPON REQUEST

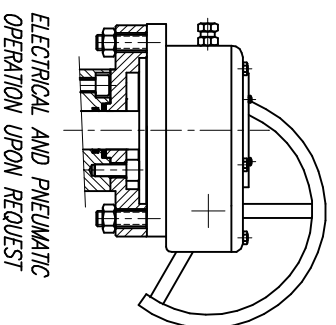

ELECTRICAL AND PNEUMATIC OPERATION UPON REQUEST

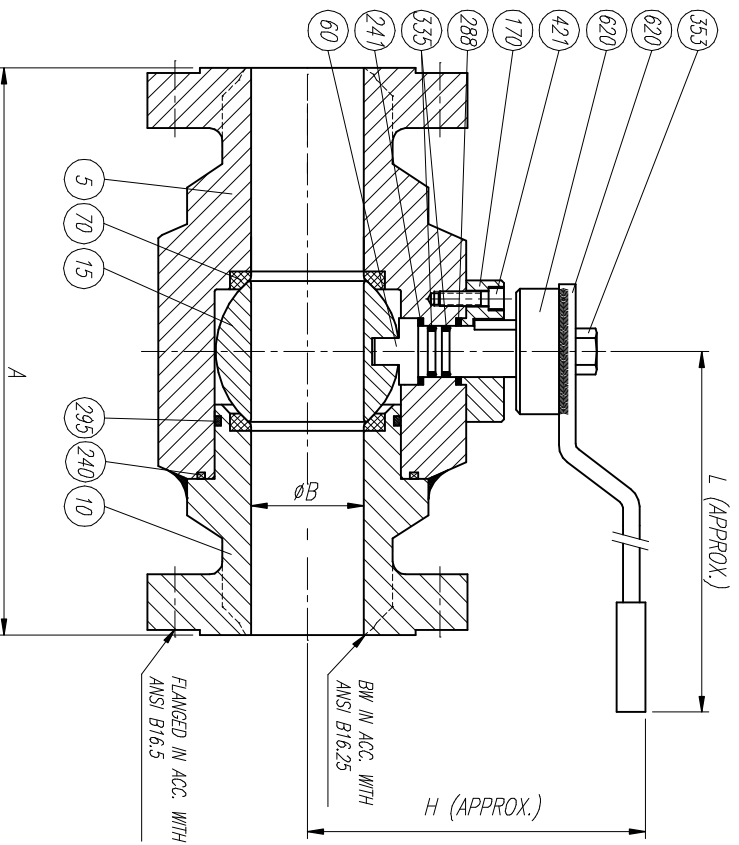

SIZE	A				ØB	ØC	H	H1	L	WEIGHT
	BW	RF	RTU							
1/2"	216	216	216	11	—	73	—	150	12	
3/4"	229	229	229	20	11	75	73	180	17	
1"	254	254	254	25	20	78	75	180	20	
1 1/2"	305	305	305	38	25	100	78	280	35	
2"	368	368	371	51	38	136	100	280	50	
3"	470	470	473	76	51	165	136	GEAR	75	

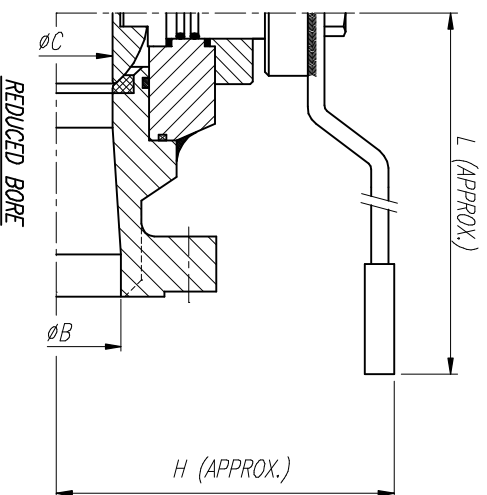

REV	Description	Detail	Drawn	Date	Appr	Date

Drawn	JLO	Date	20/12/03	Gen Tol ± 0.4	Scale	AS	Size	AS	Drawg No	BR15FS1	REV	0
Appr												

		GENERAL ASSEMBLY & LIST OF MATERIALS	
RINGO VALVULAS		FLOATING BALL VALVE 1500#	