

LIST OF MATERIALS

POS.	DESCRIPTION
5	BODY
15	DISC
60	SHAFT
164	ADJUSTING RING
555	SPRING WASHER
565	DISC WASHER
595	SPRING
660	PLUG
701	STOP PIN

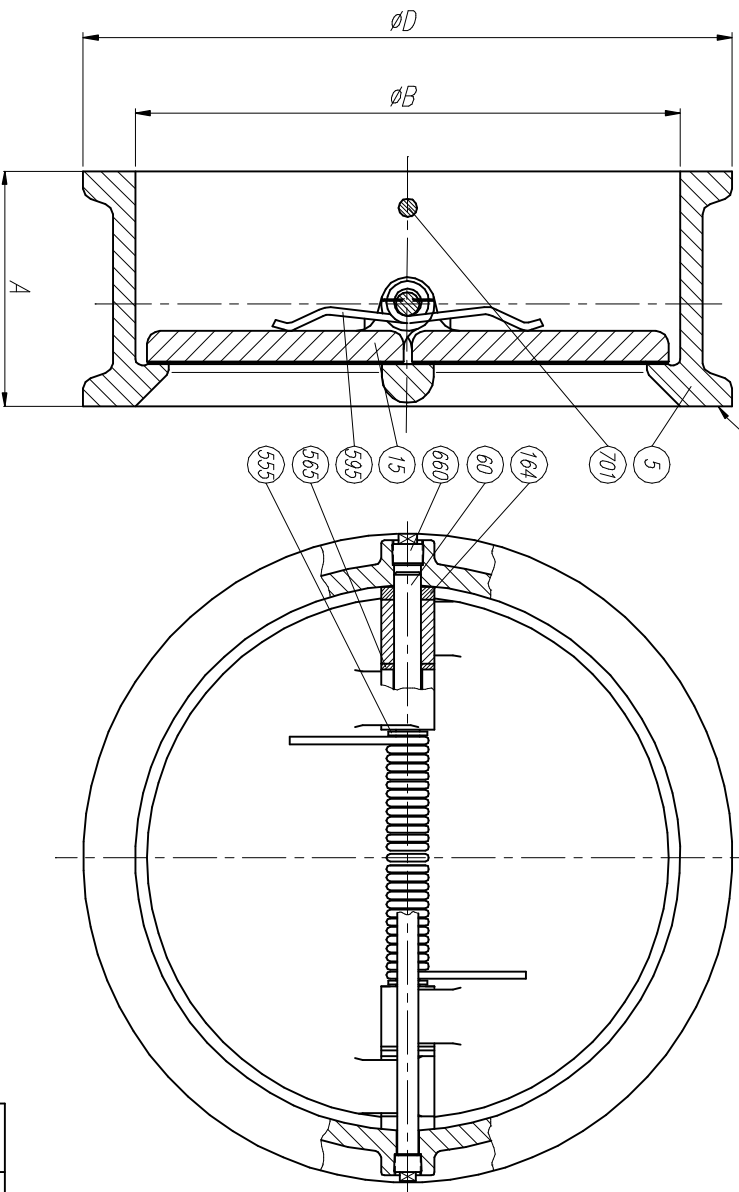

SIZE	A	ϕB	ϕD	WEIGHT
2"	60	56	103	2
2 1/2"	67	73	122	3
3"	73	88	135	4
4"	73	108	173	6
5"	86	132	196	8
6"	98	160	222	13
8"	127	210	279	25
10"	146	266	339	39
12"	181	310	409	54
14"	184	355	450	80
16"	191	405	514	117
18"	203	455	549	138
20"	219	505	606	163
24"	222	605	717	331
28"	305	700	774	380
30"	305	750	825	425
36"	368	903	985	640
42"	432	1055	1144	960
48"	524	1205	1304	1400

REV	Description	Drawn	Date	Appr	Date

		Detail: DUO CHECK VALVE 150#	
Title: GENERAL ASSEMBLY & LIST OF MATERIALS		Title: DUO CHECK VALVE 150#	
Drawn	JLO	Date	12/12/03
Appr		Scale	AS
		Gen Tol ± 0.4	
		Sheet 1 / 1	
		Size	A3
		Drawg No	RR01DC
		REV	0