

LIST OF MATERIALS	
POS.	PART NAME
5	BODY
15	DISC
20	BONNET
45	HINGE
46	HINGE PIN
70	SEAT RING
112	DISC NUT
235	BODY BONNET GASKET
271	HINGE PIN GASKET
355	BODY BONNET STUD
360	BODY BONNET STUD NUT
415	EYEBOLT
559	DISC NUT WASHER
651	NAMEPLATE
660	PLUG
700	DISC PIN

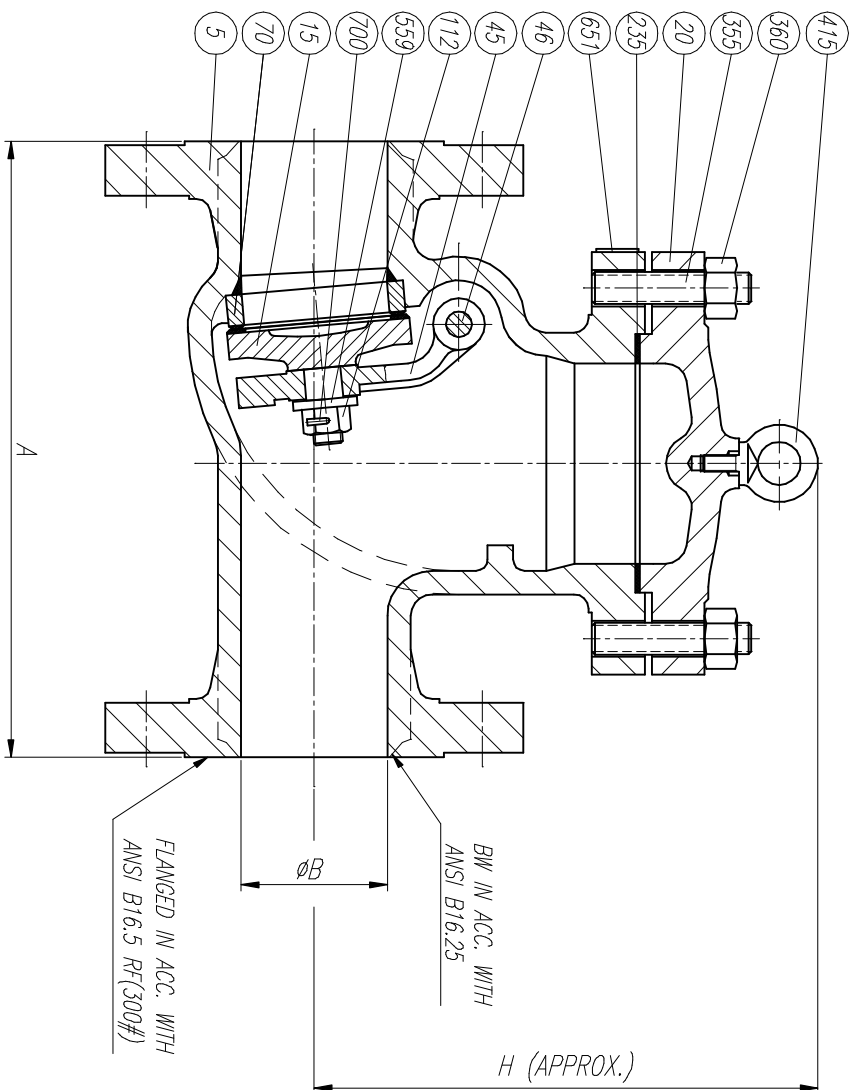

SIZE	A	ØB	H	WEIGHT
2"	267	50.8	178	23
2 1/2"	292	63.5	180	34
3"	318	76.2	216	41
4"	356	101.6	241	68
6"	445	152.4	305	125
8"	533	203.2	368	196
10"	622	254.0	394	292
12"	711	304.8	445	450
14"	838	336.6	470	688
16"	864	387.4	533	860
18"	978	438.2	584	1060
20"	1016	489.0	610	1289
24"	1346	590.6	757	1650
28"	1498	685.8	885	3000
32"	1727	787.4	1016	3700
36"	2082	889	1143	4300

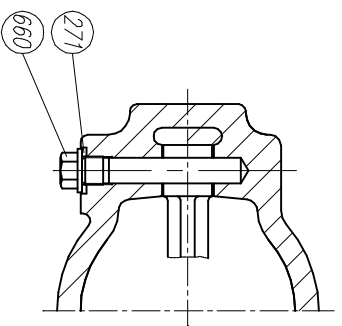

REV	Description	Drawn	Date	Appr	Date

		Description Detail GENERAL ASSEMBLY & LIST OF MATERIALS		Title: CHECK VALVE 300#	
Drawn	JLO	Date	1/12/03	Gen Tol ± 0.4	Scale -
Appr				Sheet 1 / 1	Size A3
					Drwg No RR0342
					REV 0