

LIST OF MATERIALS

POS.	DESCRIPTION
5	BODY
15	DISC
60	SHAFT
164	ADJUSTING RING
555	SPRING WASHER
565	DISC WASHER
595	SPRING
660	PLUG
701	STOP PIN

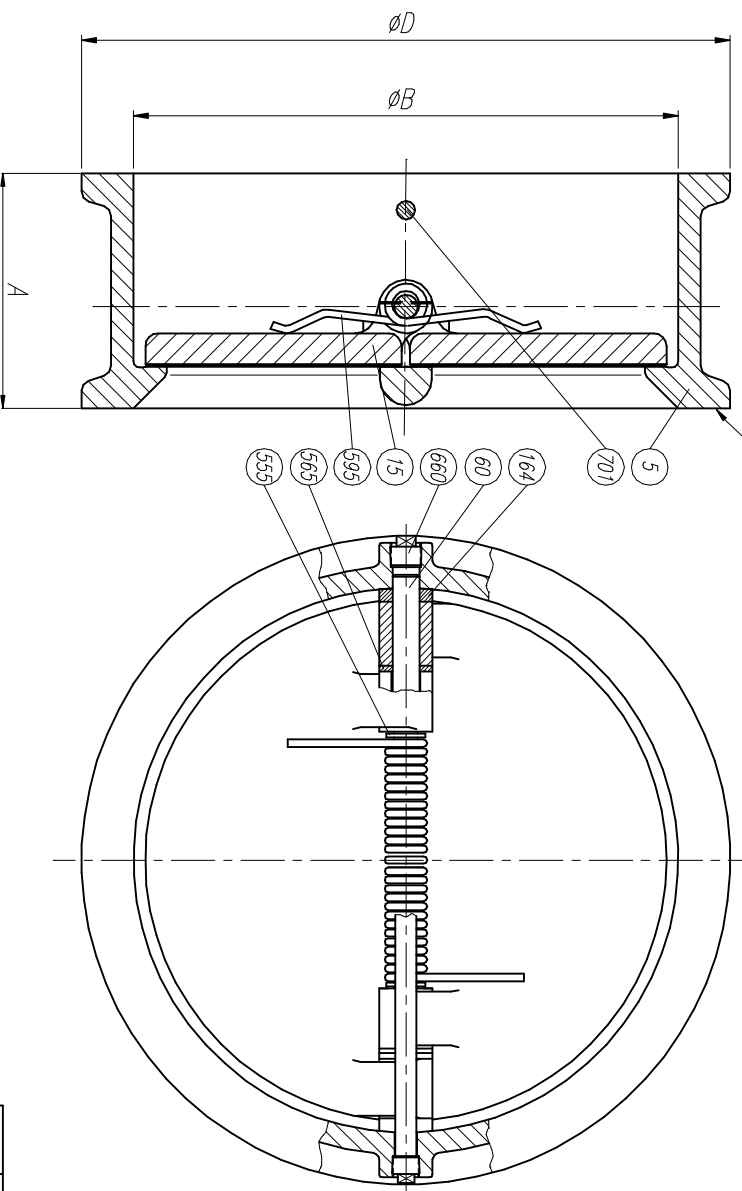

TO BE MATCHED WITH FLANGES (ANSI B16.5 RF)

SIZE	A	ØB	ØD	WEIGHT
2"	60	58	110	4
2 1/2"	67	73	128	5
3"	73	88	147	8
4"	79	108	191	11
5"	105	136	239	20
6"	136	162	264	26
8"	165	212	318	55
10"	213	266	398	95
12"	229	312	455	140
16"	305	400	562	200

REV	Description	Drawn	Date	Appr	Date

		Detail Description: RINGO VALVULAS Title: DUO CHECK VALVE 600#	
Drawn	JLO	Date	12/12/03
Appr		Gen Tol	± 0.4
		Scale	1 / 1
		Size	A3
		Drawg No	RR060C
		REV	0