

LIST OF MATERIALS	
POS.	PART NAME
5	BODY
15	DISC
20	BONNET
45	HINGE
46	HINGE PIN
70	SEAT RING
112	DISC NUT
235	BODY BONNET GASKET
271	HINGE PIN GASKET
355	BODY BONNET STUD
360	BODY BONNET STUD NUT
415	EYEBOLT
559	DISC NUT WASHER
651	NAMEPLATE
660	PLUG
700	DISC PIN

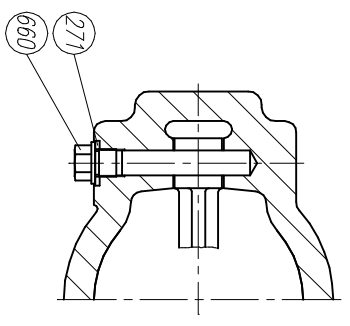
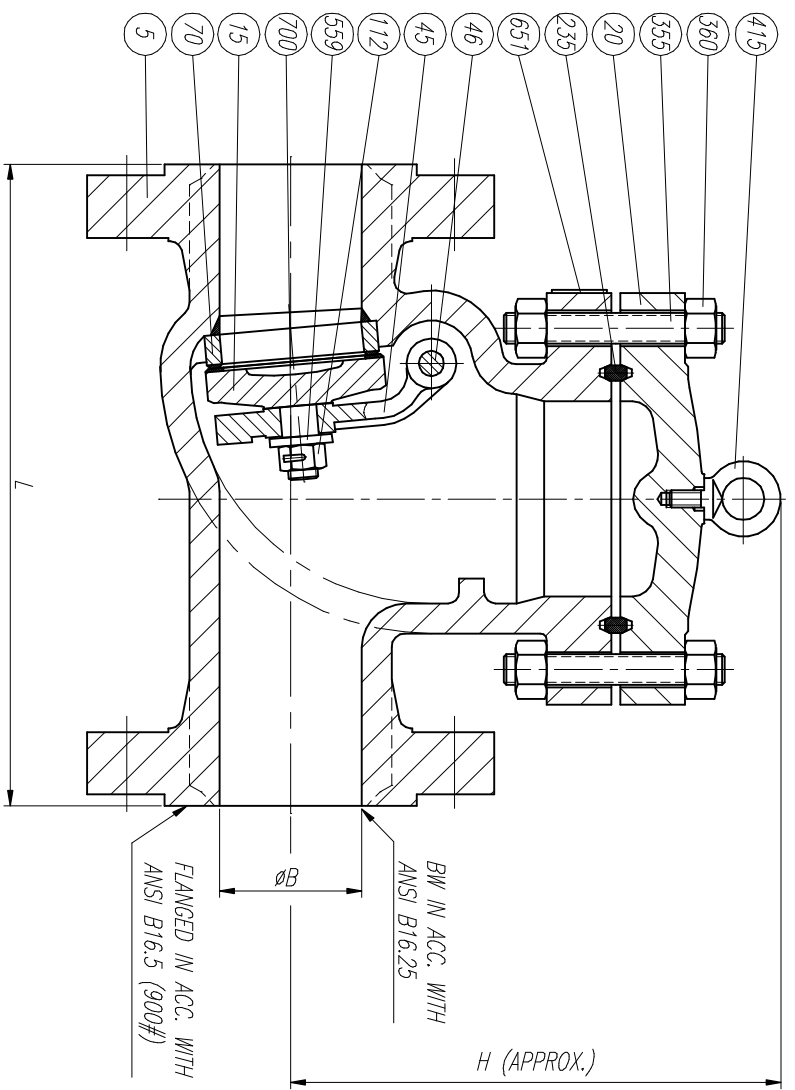

SIZE	L	ØB	H	WEIGHT
2"	368.3	51	216	80
3"	381	73	292	90
4"	457.2	98	318	150
6"	609.6	146	368	250
8"	736.6	191	432	420
10"	838.2	238	546	670
12"	965.2	283	660	1025
14"	1028.7	311	696	1400
16"	1130.3	356	778	1720
18"	1219.2	400	808	1995
20"	1320.8	445	858	2425

REV	Description	Drawn	Date	Appr	Date

Drawn	JLO	Date	1/11/03	Gen Tol ± 0.4	Scale -	Size	A3	Drawg No	RR09A2	REV	0
Appr				Sheet 1 / 1							

		<b>RINGO VALVULAS</b> GENERAL ASSEMBLY & LIST OF MATERIALS		Title: CHECK VALVE 900#	
--	--	--	--	----------------------------	--