

TO BE MATCHED WITH FLANGES (ANSI B16.5 RF)

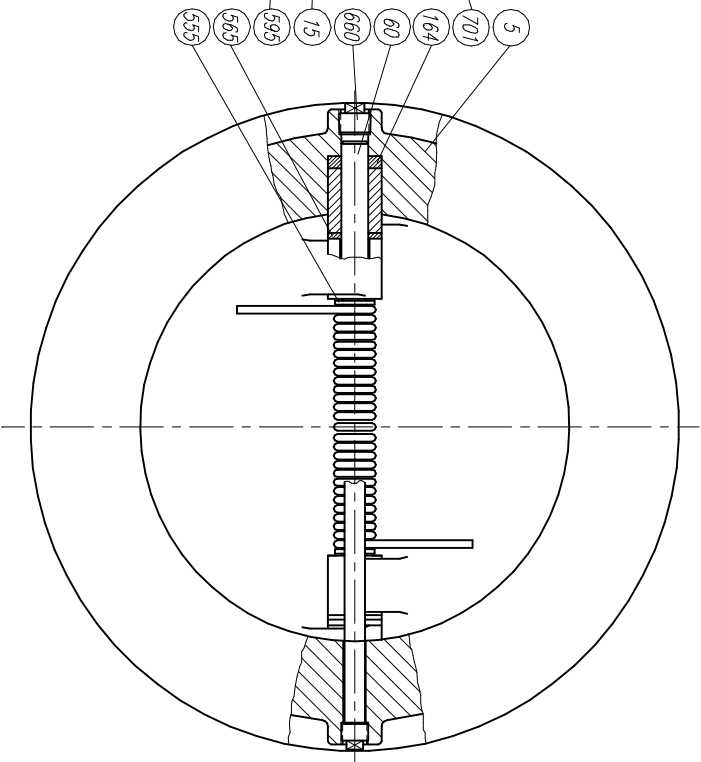

LIST OF MATERIALS	
POS.	DESCRIPTION
5	BODY
15	DISC
60	SHAFT
164	ADJUSTING RING
555	SPRING WASHER
565	DISC WASHER
595	SPRING
660	PLUG
701	STOP PIN

SIZE	A	ØB	ØD	WEIGHT
2"	70	56	140	8
2 1/2"	83	73	162	11
3"	83	88	165	14
4"	102	108	204	20
5"	127	135	245	30
6"	159	162	286	42
8"	206	212	356	84
10"	241	266	432	145
12"	292	312	495	220

REV	Description	Drawn	Date	Appr	Date

		RINGO VALVULAS <small>ESP/M</small>		Detail: DUO CHECK VALVE 900#	
Drawn: JLO		Date: 12/12/03		Title: DUO CHECK VALVE 900#	
Appr:		Date: 12/12/03		Drawn No: RR09DC	
Scale:		Sheet: 1 / 1		Rev: 0	