

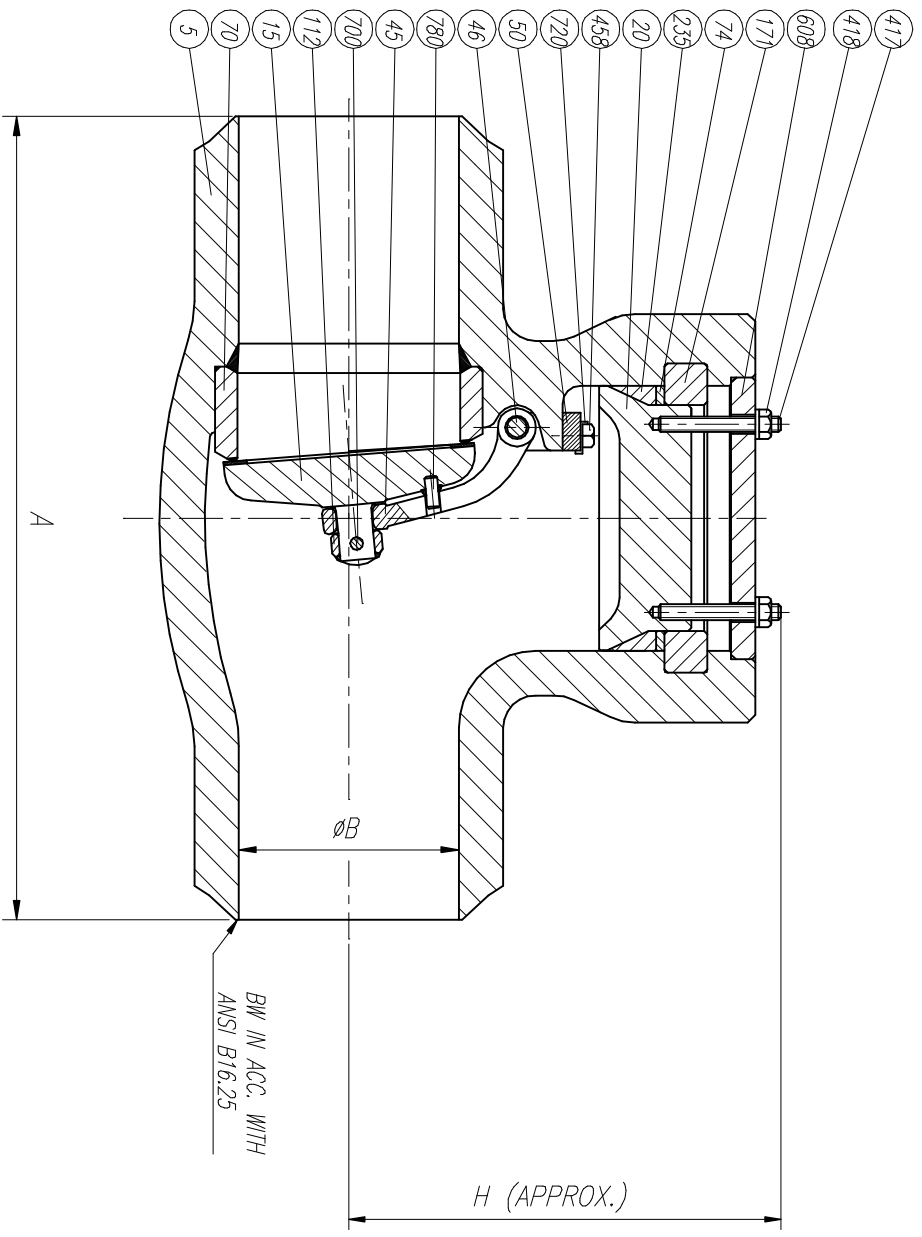

LIST OF MATERIALS

POS.	PART NAME
5	BODY
15	DISC
20	BONNET
45	HINGE
46	HINGE PIN
50	HINGE SUPPORT
70	SEAT RING
74	PROTECTION RING
112	DISC NUT
171	RETAINING RING
235	BODY BONNET GASKET
417	SULECTION BONNET STUD
418	SULECTION BONNET STUD NUT
458	HINGE SUPPORT BOLT
608	FIXATION BONNET PLATE
700	DISC NUT PIN
720	FIXATION BOLT PLATE
780	DISC STOP PIN



SIZE	A(BW)	ØB	H	WEIGHT
3"	304	69.8	254	70
4"	406	91.9	279	115
6"	558	136.4	368	250
8"	711	177.8	485	470
10"	863	222.2	585	800
12"	990	263.3	585	1350
14"	1066	288.7	660	1800
16"	1193	330.2	665	2200
18"	1346	371.3	765	2600
20"	1473	415.7	838	3400
24"	1752	498.3	965	4000

REV	Description			Detail		Drawn		Date	Appr	Date	
 ESPMA RINGO VALVULAS GENERAL ASSEMBLY & LIST OF MATERIALS											
Drawn	JLO	Date	25/03/04	Gen Tol	± 0.4	Scale	—	Size	A3	Drwg No	RR15PS2
Appr				Sheet	1 / 1						REV
											0
Title: PRESSURE SEAL CHECK 1500#											