

LIST OF MATERIALS

POS.	PART NAME
5	BODY
15	DISC
20	BONNET
45	HINGE
46	HINGE PIN
70	SEAT RING
74	PROTECTION RING
171	RETAINING RING
235	BODY BONNET GASKET
377	HINGE SUPPORT STUD NUT
417	SUCTION BONNET STUD
418	SUCTION BONNET STUD NUT
458	HINGE SUPPORT STUD
608	FIXATION BONNET PLATE
720	FIXATION BOLT PLATE
780	DISC STOP PIN

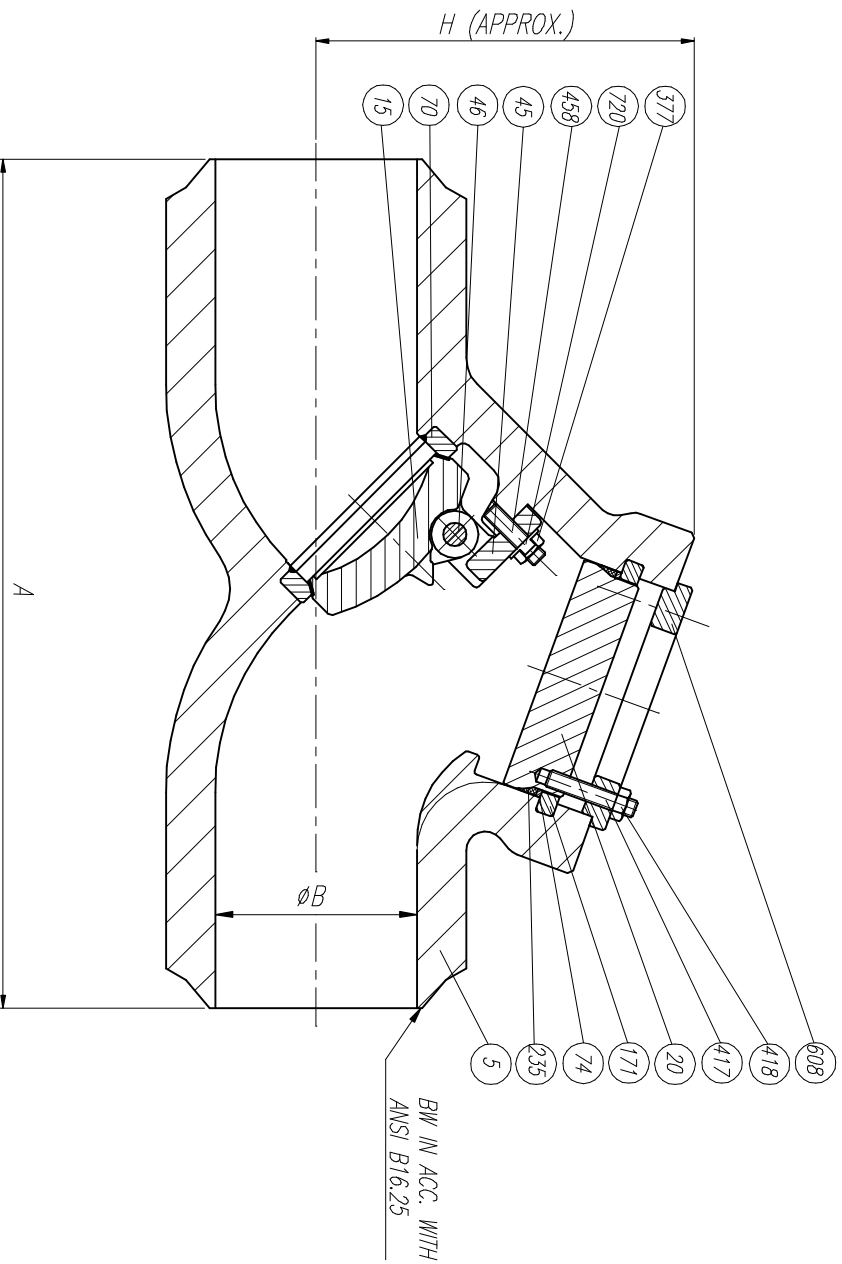

SIZE	A(BW)	ØB	H	WEIGHT
3"	368	57.1	254	120
4"	457	72.9	279	220
6"	609	111	368	540
8"	762	146	535	920
10"	914	184.1	635	1630
12"	1041	219	685	2300
14"	1117	241.3	735	3000
16"	1244	276	790	3775
18"	1397	311.1	815	4700
20"	1397	342.9	865	5500
24"	1524	412.8	1020	7000

REV	Description	Drawn	Date	Appr	Date

		RINGO VALVULAS GENERAL ASSEMBLY & LIST OF MATERIALS		Title: TILTING DISC VALVE 2500#	
Drawn	JLO	Date	26/03/04	Scale	—
Appr		Sheet	1 / 1	Size	A3
				Drawg No	RR25PS3
				REV	0